



**CROLL REYNOLDS**  
VACUUM SYSTEMS



*Precision Engineering for the Process Industries*







# EJECTORS

## Steam Jet Ejector Operation

Steam jet ejectors offer a reliable and economical means for producing vacuum. The primary advantages of the steam jet ejector are its low initial cost, lack of moving parts, and simplicity of operation.

Conventional steam jet ejectors have four basic parts: the steam chest, the nozzle(s), the mixing chamber and the diffuser. The adjacent diagram illustrates basic ejector operation: a high pressure motivating fluid enters at 1 and expands through the converging-diverging nozzle to 2; suction fluid enters at 3 and mixes with the motivating fluid in the mixing chamber 4; both are then recompressed through the diffuser to 5.

Croll Reynolds' exclusive ejector design, represents a century of innovation.

## Ejector Construction

The simplicity of the Croll Reynolds Ejector design permits fabrication from any workable or weldable material such as: cast iron, carbon steel, stainless steel, Monel, Teflon, Hastelloy, Ni-Resist, Havg, graphite-lined and rubber-lined carbon steel, titanium and fiberglass reinforced plastic (FRP).

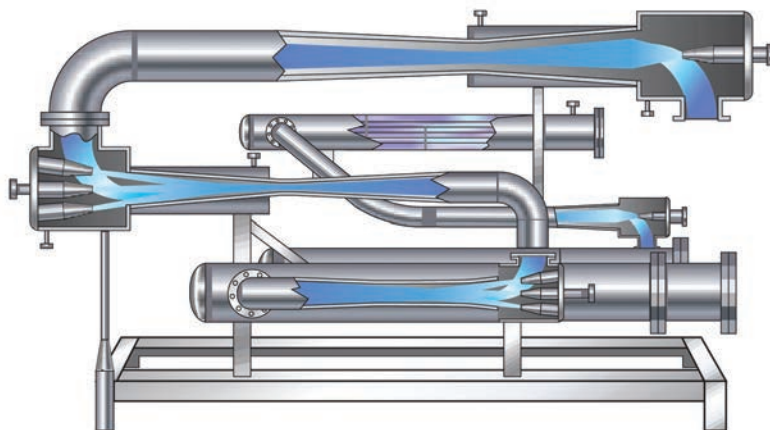

### FIVE STAGE SYSTEM

Multiple-staged systems often include surface or direct contact type condensers. Croll Reynolds' Multiple-staged systems are custom-engineered for optimum performance and minimum utility consumption.

## Multiple-Stage Ejectors

Single-stage Ejectors are used to create vacuum ranging from atmosphere to 3" Hg absolute. Higher vacuum, ranging from 3" Hg absolute to 3 microns Hg absolute, may be achieved by multiple staging. Multiple-staged systems often include surface or direct contact type condensers. Intercondensers reduce motive steam requirements and, under certain conditions, permit recovery of product condensate.

Croll Reynolds' multiple-staged systems are custom-engineered for optimum performance and minimum utility consumption. They are designed to handle a variety of process gases including air, water, HCl, butane, SO<sub>2</sub>, ethylene glycol, and many other organic and inorganic vapors. Where conditions warrant, corrosion-resistant materials of construction are utilized. While most Ejectors are steam motivated, other fluids can be used. For example, to maintain the purity of a product, a process compatible fluid can serve as the motive fluid.

Croll Reynolds supplies complete packaged, turnkey systems which include Ejectors, Condensers, Interconnecting Piping, Instrumentation, and Electronic Controls.

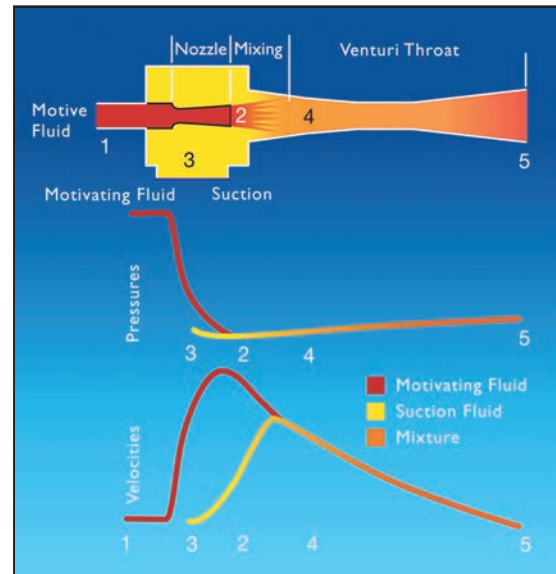

### BASIC EJECTOR OPERATION

A high pressure motivating fluid enters at 1 and expands through the converging-diverging nozzle to 2; the suction fluid enters at 3 and mixes with the motivating fluid in the mixing chamber 4; both are then recompressed through the diffuser to 5.

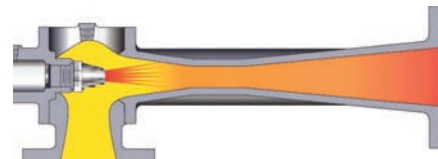

### SINGLE-NOZZLE EJECTOR

Single-Nozzle Ejectors are used for either critical or non-critical flow, but usually for only one set of design conditions.



### MULTIPLE NOZZLE EJECTOR

Croll Reynolds Multiple-Nozzle Ejectors are unique in both design and performance. In most cases, they offer steam savings of 10% to 20% when compared with single-nozzle units designed for the same conditions.

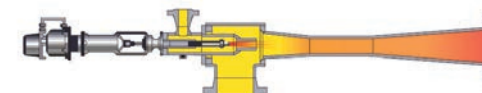

### SPINDLE-OPERATED EJECTOR

Spindle-Operated Ejectors are indicated wherever suction or discharge pressures vary. During operation, a pneumatically-driven tapered spindle moves in and out of the nozzle orifice to control motive fluid flow.

For further information, visit [www.croll.com](http://www.croll.com)

# ROTAJECTOR®

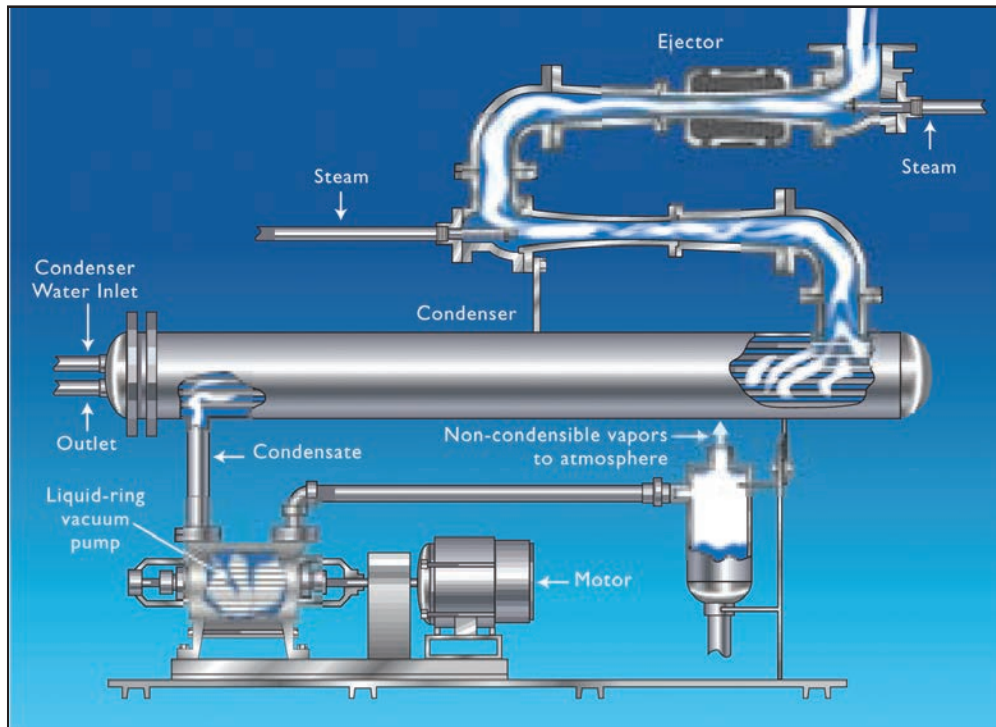

- *Reliable high vacuum*
- *Designed for use with low pressure steam*
- *Reduced steam consumption*
- *Designed for low elevation installation*
- *Low purchase and operation costs*
- *Custom-designed for each application*

*In this low-maintenance system, the only moving part is the impeller of the liquid-ring vacuum pump. And, no special vacuum oils, lubricants or special cooling systems are needed.*

Rising energy costs have created an increased demand for process vacuum systems which operate at the lowest possible cost. In response, Croll Reynolds developed the Rotajector; a combined Ejector/Condenser/ Liquid Ring Pump high vacuum system.

## Operation

In a typical rotajector, process gases or vapors are drawn into the suction port of the first stage Ejector and compressed by subsequent stages. The condenser cools the gases and condenses the vapors, thus reducing the load to the liquid ring vacuum pump, which serves as the final compression stage. The pump also handles condensate, eliminating the need for a condensate removal pump.

## Configurations

Croll Reynolds Rotajector systems are manufactured in up to six-stage configurations and in a wide range of capacities. Design and configuration flexibility makes the Rotajector a highly versatile vacuum system, readily adapted to a variety of process applications.

## Chemical Industry

High efficiency Rotajector systems, designed for operation with low pressure steam, are used for process applications including distillation, evacuation, drying, crystallization, evaporation and cooling.

## Pharmaceutical Industry

Vacuum drying at a relatively low

temperature is critical in many pharmaceutical applications where heat sensitive compounds might be destroyed by alternative drying methods.

## Food Industry

The high vacuum created by a Rotajector results in flash evaporative cooling of food products – thus preserving flavor, color and freshness without the need for preservatives or flavor enhancing additives. For chilling just-cooked foods, Rotajectors offer the advantage of using the same low pressure steam source that is used for cooking.

For further information, visit [www.croll.com](http://www.croll.com)

# THERMOCOMPRESSORS

- Reclaim waste steam
- Reduce steam/water consumption
- Custom-designed
- Single-Nozzle, Multiple-Nozzle and Spindle-Operated configurations

In theory, a Thermocompressor and an Ejector are identical. The difference lies only in the application. Ejectors are used to produce a vacuum. A Thermocompressor is used to entrain and compress a low pressure fluid to an intermediate reusable pressure/temperature. The resultant recompressed fluid can then be used for another process and its heat value, which might otherwise have been wasted, reclaimed. Croll Reynolds Thermocompressors are available in single-nozzle, multiple-nozzle and spindle-operated configurations. They are used throughout the Process Industries.

## Thermocompressor Operation

During operation, the mixture of motive steam and entrained fluid is recompressed through the diffuser, which converts velocity energy to pressure energy. The recompressed vapor can be reclaimed for return to the process.

## Paper Industry

Thermocompressors compensate for changes in the temperature and discharge



pressures of steam dryers while reclaiming waste steam.

## Pharmaceutical Industry

Heat-sensitive chemicals are usually vacuum dried at relatively low temperatures. Thermocompressors operate efficiently at these temperatures and therefore provide an excellent means for reclaiming waste steam.

## Food Industry

Tomato paste and other food concentrates, as well as dairy products,

are produced in evaporators and dryers. Thermocompressors recover the vapors removed from food products during the concentration process.

## Chemical Processing and Petrochemical Industries

Dyers, stills, strippers and deodorizers usually discharge water vapor at relatively low pressures. Thermocompressors reclaim this vapor.



*Multiple-Nozzle assembly*

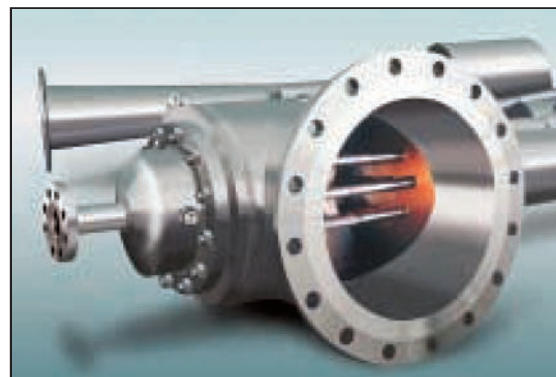

*Multiple-Nozzle assembly viewed through the suction connection.*

For further information, visit [www.croll.com](http://www.croll.com)



# POWER SYSTEMS



## OPERATION:

Air and non-condensable vapors from the main condenser, enter the first stage ejector suction connection. High pressure steam enters the steam chest and expands to the suction pressure through a properly designed steam nozzle. Steam exits from the nozzle at high velocity, and entrains the air and non-condensable vapors compressing them to a higher pressure by means of a converging-diverging throat. The mixture then enters an intercondenser where the steam is condensed. The intercondenser compartments are designed with special internal baffles and arranged to allow the air to be cooled to the lowest possible temperature thereby reducing the volume of the air/vapor mixture to a minimum before it enters the second stage ejector. The second stage ejector handles the air/vapor mixture in the same manner as the first, and the steam/air mixture from the second stage enters an aftercondenser where the action is similar to that in the intercondenser. Air exits the discharge vent opening at a low temperature to reduce heat loss. The air flow can be measured by means of a rotameter. To rapidly reduce main condenser pressure during start up, priming ejectors (a.k.a. hoggers) are commonly installed in parallel with the unit. These ejectors are designed to handle large capacities for the rapid initial evacuation. Noise levels sometimes exceed OSHA maximum levels, and silencers are often installed to bring noise to acceptable levels.

The efficiency of steam turbines in a power plant directly correlates to the pressure of the steam that exits the turbine. A surface condenser operating under vacuum is typically installed to capture and condense steam exiting the turbine. The resultant turbine efficiency translates into added megawatts of electricity.

Condenser vacuum is typically achieved by a steam jet air ejector system.

The customary ejector system for this service is a two stage, twin element type vacuum unit, having duplicate ejectors for each stage, one running and one on standby, with a hogger (startup ejector) and a silencer all mounted with inter and after condensers, complete with valves and instrumentation.

Croll Reynolds' systems efficiently remove non-condensable vapors and associated water vapor from the surface condenser, and lower the pressure (achieving vacuum) in the condenser and at the turbine outlet.

Croll Reynolds' experience in sizing ejector systems for steam turbines and surface condensers is unparalleled. Each system is custom designed to the closest tolerances with a view towards the highest system efficiency. Croll Reynolds' power systems have found wide acceptance due to their small space requirements, simplicity of operation, reliability, low maintenance and quick starting characteristics.

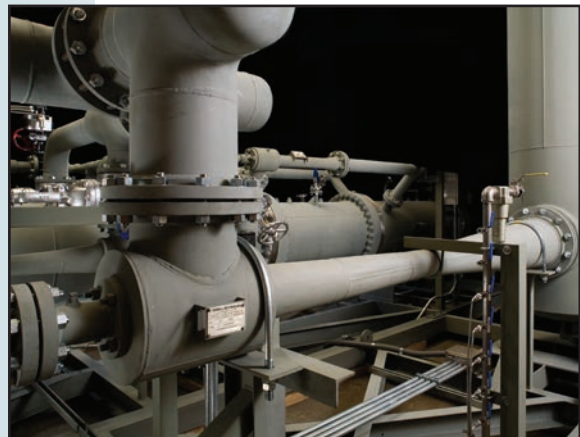

# DESUPERHEATERS

Superheated steam is pressurized water vapor that is at a temperature higher than the saturation temperature of the steam pressure. Although process steam is typically throttled and superheated for efficient distribution, it must be cooled before it is condensed and therefore it is less efficient than saturated steam for a majority of heat transfer applications. The most efficient way to reduce the superheat value of steam is by “desuperheating” it. This involves the direct introduction of water to the steam.

**Superheated steam:**

- *Increases cycle time for heat transfer;*
- *Yields lower rates for heat transfer;*
- *Creates temperature gradients over heat transfer surfaces, and thereby effects product quality; and,*
- *Requires larger heat transfer area and thereby increases design and installation cost*

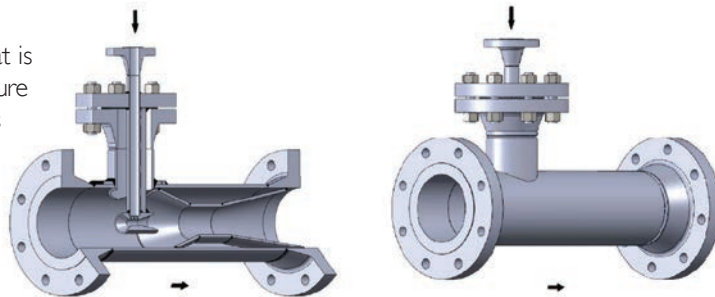

**DOUBLE VENTURI DESUPERHEATERS**

Desuperheaters are usually supplied with pressure and temperature controllers, actuators, steam pressure reducing valves and water control valves as part of an engineered system. With nearly 100 years of experience in the design and manufacture of steam systems, Croll Reynolds' Desuperheaters offer proven efficiency and guaranteed process performance.

Croll Reynolds offers a full line of desuperheater configurations: Fixed Nozzle Desuperheaters; (Hollow Cone); Venturi Desuperheaters (Attemperator); Double Venturi Desuperheaters; and, Full Venturi Desuperheaters. Croll Reynolds specializes in the custom design of engineered systems. Please contact us with your specific requirements.

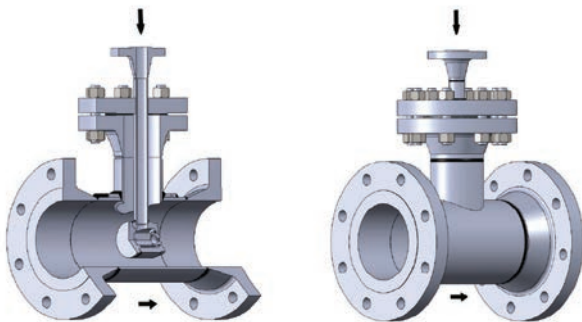

**FIXED NOZZLE DESUPERHEATERS HOLLOW CONE**

Desuperheaters are utilized in the power industry for boiler heat recovery systems, in the pulp and paper industry for the control of dryer drum temperature, for optimal heat transfer in surface condensers, and for a myriad of other process and refinery applications where make-up steam is required or where process conditions require the control of excess temperature.

Croll Reynolds' Desuperheaters are custom designed and manufactured to optimize the temperature reduction of superheated steam which increases its energy exchange capacity and results in ideal heat transfer efficiency.

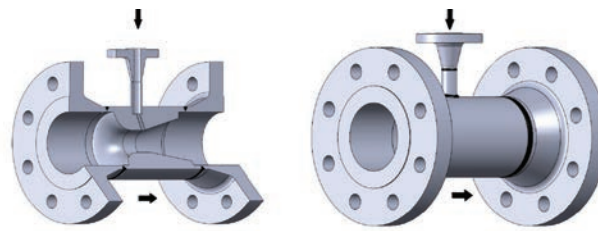

**FULL VENTURI DESUPERHEATER**

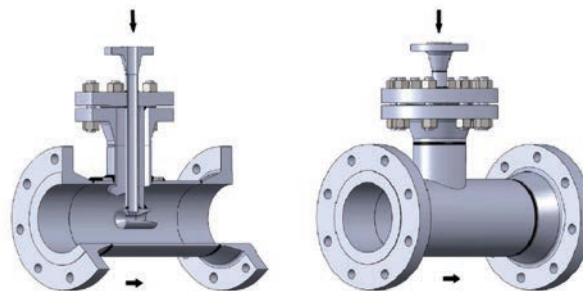

**VENTURI DESUPERHEATERS ATEMPERATOR**

**CROLL REYNOLDS**  
VACUUM SYSTEMS

**VACUUM CHILLERS**

**RAPID CHILLING WHERE LARGE FLOW RATES ARE REQUIRED**

A series of Ejectors reduce pressure in the chill tank resulting in the flash evaporation of the incoming water. The latent heat of vaporization required in this phase change is supplied by liquid resulting in a lower liquid temperature. Each stage of the system achieves successively lower liquid temperatures.

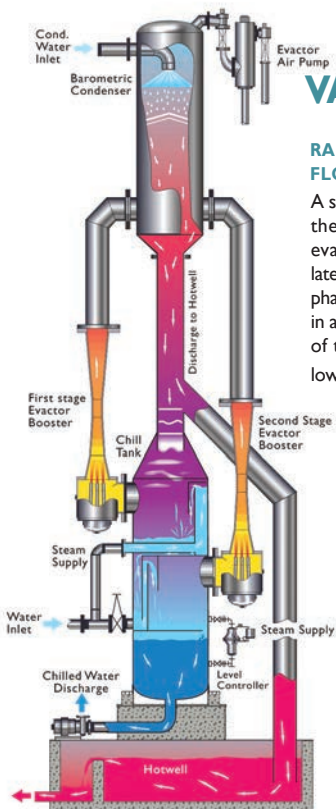

- *Highly reliable chilling systems*
- *Deaerate liquids as they are chilled*
- *Custom-designed*
- *Eliminate hazardous and corrosive refrigerants*
- *Designed for outdoor installation*
- *Require no operating supervision*
- *Virtually maintenance free*

**CHILL-VECTOR**

Chill-Vectors are used where large flow rates of cool water are continuously required, such as in the paper and pharmaceutical industries.

The Croll Reynolds Chill-Vector is a highly reliable vacuum flash cooling system with applications in water chilling, food processing and a variety of industrial uses. Chill-Vectors installed as long as forty years ago are still in operation.

Automatic controllers can be added to enhance Chill-Vector efficiency by reducing energy used during off-peak demand periods. For example, a ratio controller will provide up to 40% in steam savings by throttling motive steam pressure when condensing water temperature is below design specifications.

**Paper Industry**

Chill-Vectors are used for chilling and deaerating water to absorb the chlorine dioxide used in paper bleaching operations. Due to the greater solubility of chlorine dioxide in cold deaerated water, the bleaching agent is more efficiently absorbed.

**Pharmaceutical Industry**

Chill-Vectors produce the high volume of chilled water required to manufacture organic acids, vitamins, antibiotics and synthetic medicines.

**Other Applications**

Additional Chill-Vector applications include the cooling of sod, tobacco, sand, gravel and other granular materials.

**ETHYLENE GLYCOL DRIVEN VACUUM SYSTEMS**

Croll Reynolds' ethylene-glycol-driven ejector systems are designed to reduce waste and conserve energy for reactor service in the production of polyester polymers. These systems employ ethylene glycol, the process solvent, as the motive fluid (MEG) for the reactor ejectors.

Solvent recovery and the elimination of ejector fouling are major considerations in the design of vacuum pumping systems for polyester polymer reactor service. In conventional systems, ethylene glycol, the process solvent, contaminates steam condensate, while polymer carryover from the process fouls the initial stages of the system, causing frequent shutdowns for cleaning.

By utilizing the process solvent as the motive fluid, contamination of steam condensate is eliminated. MEG driven ejectors run hotter than conventional jet ejectors, and therefore fouling of

the units by polymer carryover is significantly reduced. The use of organic vapor also avoids process contamination caused by the back-streaming of steam.

The waste-reduction features of Croll Reynolds' ethylene-glycol-driven ejector designs represent a major economic advantage for those who produce polyester polymers. System efficiency is significantly enhanced due to the fact that the high-boiling-point of MEG reduces energy requirements. The ability of the design's inter-condensers to operate at lower pressures results in lower cooling media requirements, the elimination of condensate contamination and the recovery of valuable resources.

Croll Reynolds jets are designed to the closest tolerances. The use of MEG jets permits reduced nozzle velocities resulting in a significant decrease in internal erosion thus extending the service life of the design.

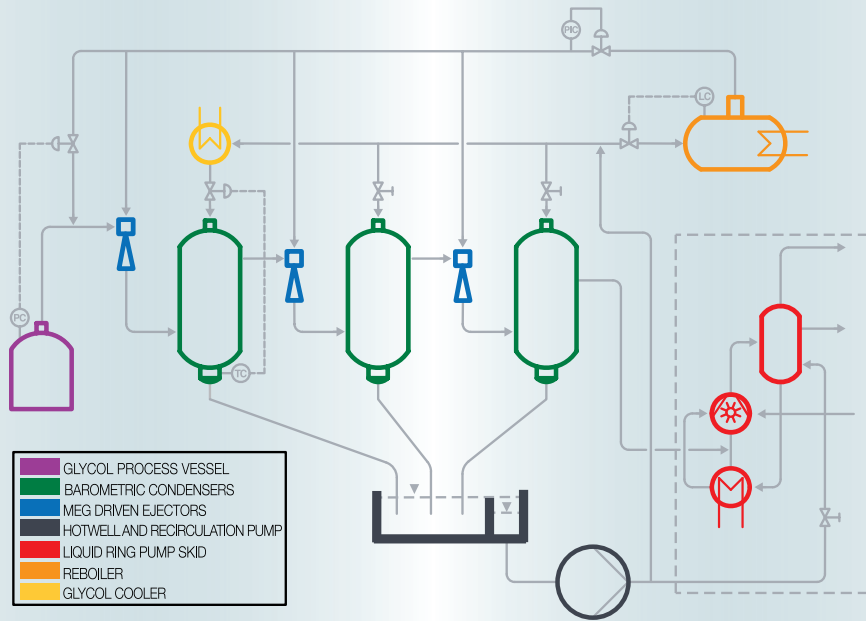



# ENGINEERING: INNOVATION-QUALITY-PERFORMANCE

## **Innovative Engineering**

Croll Reynolds' commitment to its customers begins with a thorough evaluation of such factors as applications feasibility, operational efficiency, performance requirements and cost effectiveness. The success of any installation is virtually assured before it goes on-line.

Computer Aided Design and Finite Element Analysis programs permit Croll Reynolds engineers to share information throughout the design process. Careful attention to detail during all phases of design and test results in products that consistently exceed customer expectations.

## **Life-Cycle Product Support**

Croll Reynolds stands behind every installation from design through operation. As part of its commitment to customer support, life-cycle records are maintained for every system. Records include: system and component specifications, detailed lists of parts and construction materials, and performance data.

Whenever upgrade components or replacement parts are required, they are supplied to the specifications of the original equipment – with the added benefits of enhancements in technology, design, materials and production techniques.

## **Operational and Application Support**

Croll Reynolds engineers are always available to assist with application and technical matters as well as with system operation. Croll Reynolds field representatives are trained in the technical and operational aspects of our products.

## **Quality Manufacturing/Quality Control**

Manufacturing and test facilities in the United States, as well as in the Far East, include a wide range of state-of-the-art automated machine tools. Shop and supervisory personnel, many with more than 35 years of experience at Croll Reynolds, take pride in a total team effort. Every project is monitored by quality control professionals. All equipment is designed and manufactured to meet or exceed industry standards and all applicable codes (HEI, TEMA, RTP-1, ASME).

## **Croll Reynolds Research and Test Centers**

Croll Reynolds Research and Test Centers provide a real-world environment for the pilot development of custom systems and new product concepts.

Multiple steam generation facilities offer the flexibility and capacity required to test systems and components prior to shipment.



## PROVIDING WORLDWIDE SOLUTIONS

With Manufacturing, Research and Test facilities in the Far East as well as in the United States, and a worldwide network of representatives, Croll Reynolds has emerged as a leading supplier of high performance Process Vacuum and Air Pollution Control equipment to the world.

From the Pharmaceutical Plants of New Jersey to the Edible Oil Refineries of Brazil; from the Industrialized Plains of India to the Palm Plantations of Malaysia; Croll Reynolds is the resource for innovative engineering and unparalleled expertise.

The synergy between our Process Vacuum and Air Pollution Control technology continues to offer a powerful design and engineering advantage. Call us for the office location of the factory-trained process vacuum or air pollution control specialist nearest you.



For further information, visit [www.croll.com](http://www.croll.com)



### CROLL REYNOLDS

Croll Reynolds Company, Inc.  
 6 Campus Drive  
 Parsippany, New Jersey 07054  
 Tel. (908) 232-4200  
 Fax. (908) 232-2146  
 Web Site: [www.croll.com](http://www.croll.com)  
 Email: [info@croll.com](mailto:info@croll.com)

